

SPECIALTY ARTS

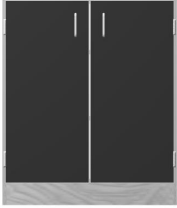

All TMI catalog sections are available online at: www.tmisystems.com/products/reference

TMI PRODUCT NO.	PERSPECTIVE	DESCRIPTION	W	H	D
 B9472		Double door damp storage base cabinet with two adjustable expanded metal shelves and a metal drip pan on the bottom.	24"	30"	14"
			27"	34"	18"
			30"	36"	24"
			33"		29"
			36"		

TMI PRODUCT NO.	PERSPECTIVE	DESCRIPTION	W	H	D
 T9453		Drawing board storage cabinet with one fixed shelf and two adjustable shelves. Each shelf has 1/2" x 1/2" retaining bars for drawing board storage. Storage for 32 drawing boards in 30" wide cabinets, and 44 drawing boards in 36" wide cabinets.	30"	84"	24"
			36"		29"

 T9454 T9455		Single door dry storage cabinet with two door vents, five adjustable expanded metal shelves and a metal drip pan on the bottom.	12"	72"	14"
			15"		18"
			18"		24"
			21"		29"
			24"		